

Madison, Wisconsin

CITY OF MADISON

CITY ENGINEERING DIVISION

DEPARTMENT OF PUBLIC WORKS

PLAN OF PROPOSED IMPROVEMENT

PUBLIC IMPROVEMENT PROJECT
APPROVED
MAY 1, 2018
BY THE COMMON COUNCIL
OF MADISON, WISCONSIN

PUBLIC IMPROVEMENT DESIGN
APPROVED BY:

City Engineer Date 5/10/18

INDEX OF SHEETS

SHEET NO.	TITLE
1	PROJECT LOCATION MAP
LM1	ACADEMY DR.
AD1	BRITTA DR.
BD1	DROSTER DR.
DD1-2	EDGEWOOD AVE.
EA1	MAYFAIR AVE.
MA1	REDAN DR.
RD1	TOKAY BLVD.
TB1	TURBOT DR.
TD1	WHITNEY WAY
WW1	

LOCAL ROAD TRAFFIC CALMING & ARTERIAL PEDESTRIAN ENHANCEMENTS - 2018

CITY PROJECT NO. 11587
CITY CONTRACT NO. 8126

GEOMETRICS
DESIGNED BY:

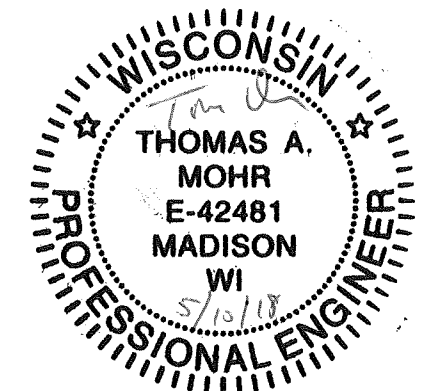

CITY-WIDE PROJECT LOCATIONS

CONVENTIONAL SIGNS	
FIELD VERIFY ALL UTILITY LOCATIONS	
GAS	— G —
STORM SEWER	— ST —
SANITARY SEWER	— SAN —
WATER	— W —
OVERHEAD ELECTRIC	— OH —
POWER POLE	⊕
ADA COMPLIANT RAMP W/ DETECTABLE WARNING FIELD	
COMBUSTIBLE FLUIDS	

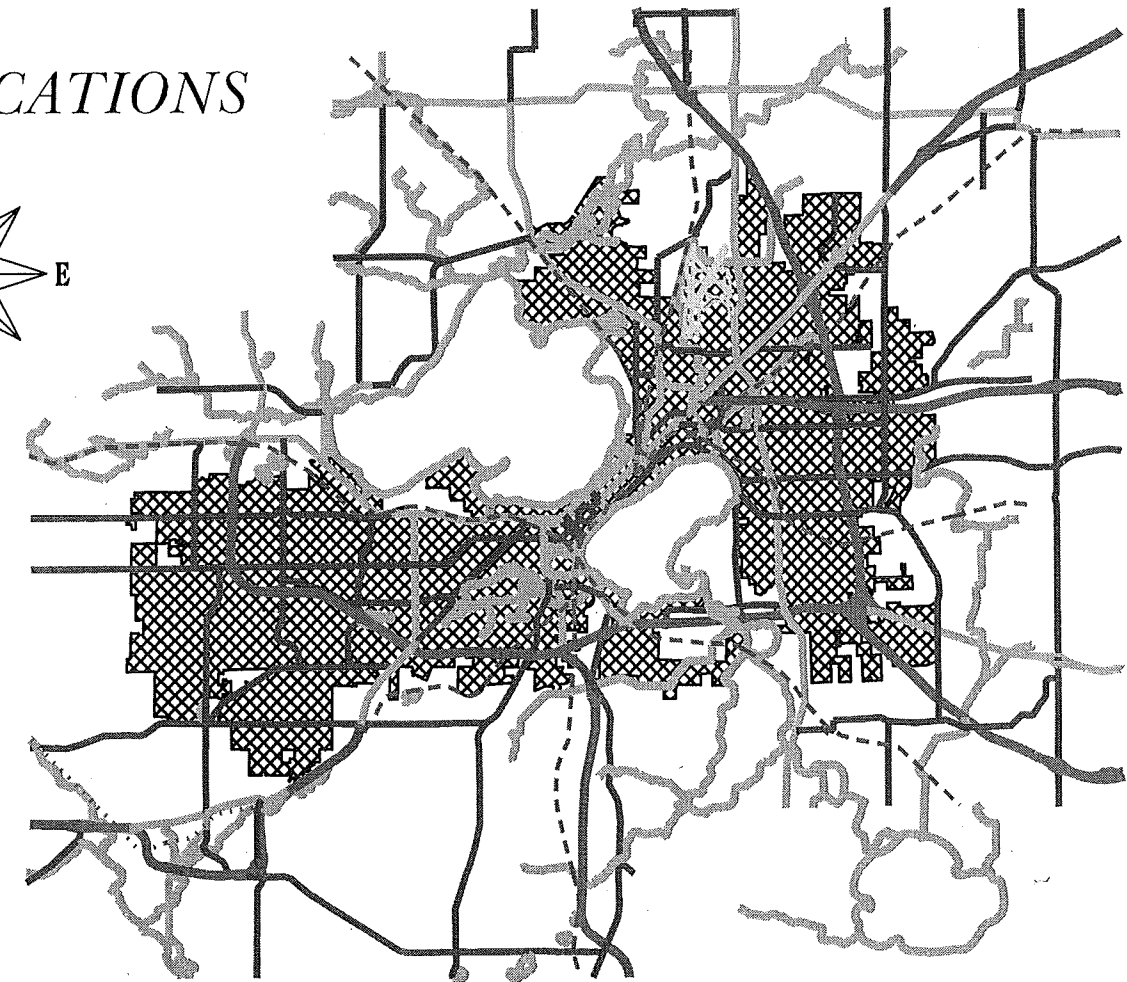
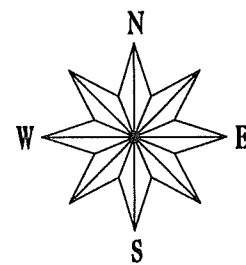

NOTES:

ALL GUTTERS SHALL DRAIN WITH A MINIMUM GRADE OF 0.50% TOWARD STORM SEWER INLETS.

SIDEWALK RAMPS AND CURB THRU SIDEWALK RAMPS SHALL HAVE A MAXIMUM SLOPE OF 1" PER 12". SIDEWALK AND CURB RAMPS SHALL BE CONSTRUCTED WITH A SIDE SLOPE OF 1.50%. SIDEWALK SHALL HAVE A MINIMUM LONGITUDINAL SLOPE OF 0.50% AND A MAXIMUM LONGITUDINAL SLOPE OF 5.00% EXCEPT WHERE STREET GRADES EXCEED 5.00%.

EARTH WORK SUMMARY:
EXCAVATION CUT (MEASURED PLAN QUANTITY).....390 C.Y.
ESTIMATED UNDISTRIBUTED UNDERCUT.....0 C.Y.
TOTAL UNCLASSIFIED EXCAVATION CUT.....390 C.Y.

WHITNEY WAY BUS PULL-OUT
DESIGNED BY:

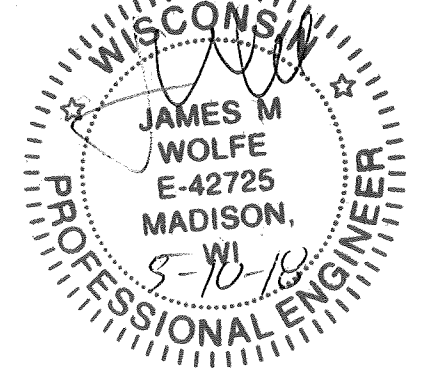

PLOT SCALE: _____
PLOT NAME: _____

REV. DATE: _____

ORIGINATOR: CITY OF MADISON - STREETS DIVISION

PLOT SCALE: _____

PLOT NAME: _____

REV. DATE: _____

ORIGINATOR: CITY OF MADISON, STREETS DIVISION

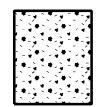

 = PROPOSED SPEED HUMPS



NOTES:

1. INSTALL SPEED HUMPS PER S.D.D. 4.10 WITH FLOW THRU GUTTER.
2. SAWCUT PAVEMENT AT EDGE OF PROPOSED SPEED HUMP. RECORDS INDICATE ASPHALT PAVEMENT.

BRITTA PKWY



NOTES:

- 1. INSTALL SPEED HUMPS PER S.D.D. 4.10 WITH FLOW THRU GUTTER.
- 2. SAWCUT PAVEMENT AT EDGE OF PROPOSED SPEED HUMPS. RECORDS INDICATE ASPHALT PAVEMENT.



1801

4300

BRITTA DR

16'

17'

16'

11'

HELENE PKWY

1809

4357

4353

4349

4345

4341

4337

4333

4329

4325

4321

1802

4362

4358

4354

4350

4346

4342

4338

4334

4330

4326

4322

1810

DE VOLIS PKWY

4300

DE VOLIS PKWY

AXEL AVE

4303

1809

1809

1813

1813

1901

1901

1905

1905

1909

1909

4401

1806

1810

1814

1818

1822

1826

1830

1902

1906

1910

1914

4362

PLOT SCALE: _____

PLOT NAME: _____

REV. DATE: _____

ORIGINATOR: CITY OF MADISON, STREETS DIVISION

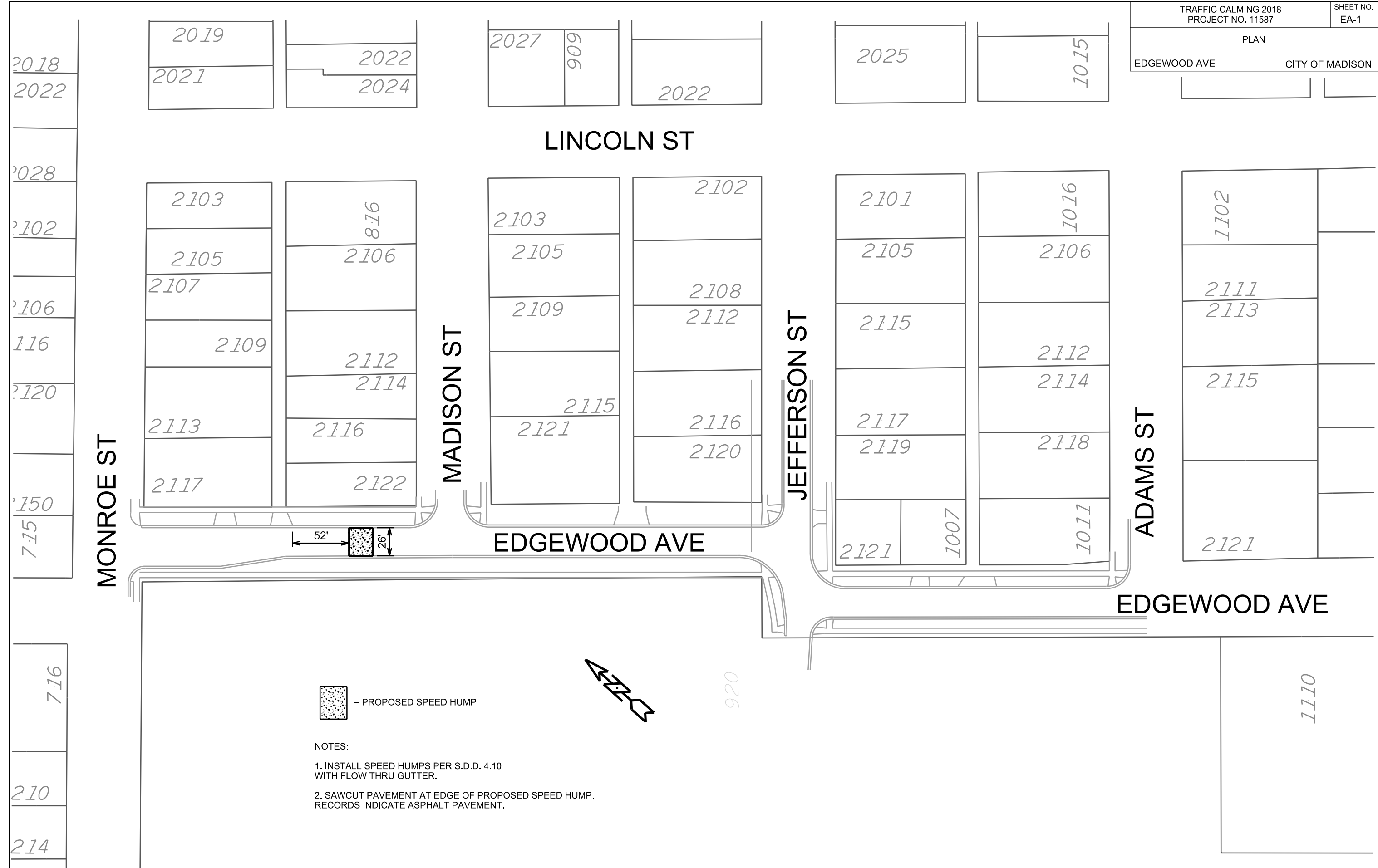

 = PROPOSED SPEED HUMPS

- NOTES:
1. INSTALL SPEED HUMPS PER S.D.D. 4.10 WITH FLOW THRU GUTTER.
 2. SAWCUT PAVEMENT AT EDGE OF PROPOSED SPEED HUMPS. RECORDS INDICATE ASPHALT PAVEMENT.

PLOT SCALE: _____

PLOT NAME: _____

REV. DATE: _____

ORIGINATOR: CITY OF MADISON, STREETS DIVISION

PLAN

MAYFAIR AVE

CITY OF MADISON



NOTES:

- 1. INSTALL SPEED HUMPS PER S.D.D. 4.10 WITH FLOW THRU GUTTER.
- 2. SAWCUT PAVEMENT AT EDGE OF PROPOSED SPEED HUMP. RECORDS INDICATE ASPHALT PAVEMENT.



PLOT SCALE:

PLOT NAME:

REV. DATE:

ORIGINATOR: CITY OF MADISON, STREETS DIVISION

VALLEY VIEW RD



= PROPOSED SPEED HUMPS

NOTES:

- 1. INSTALL SPEED HUMPS PER S.D.D. 4.10 WITH FLOW THRU GUTTER.
- 2. SAWCUT PAVEMENT AT EDGE OF PROPOSED SPEED HUMP. RECORDS INDICATE ASPHALT PAVEMENT.



REDAN DR

WEATHERSTONE RD

SHINING ROCK TRL

RUNG WAY

ANCIENT OAK LN

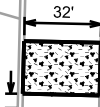
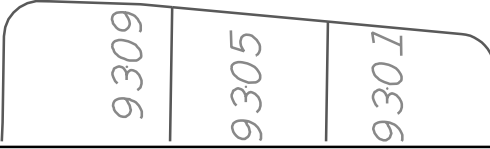
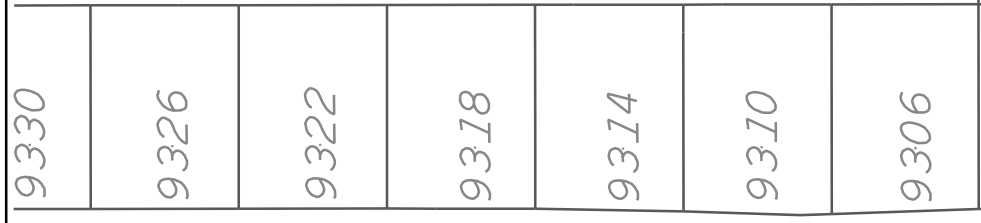
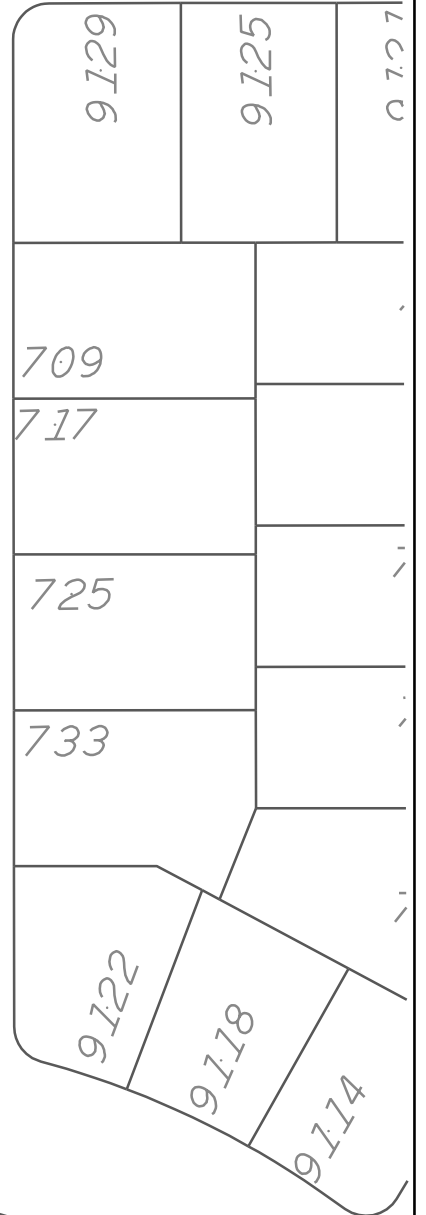
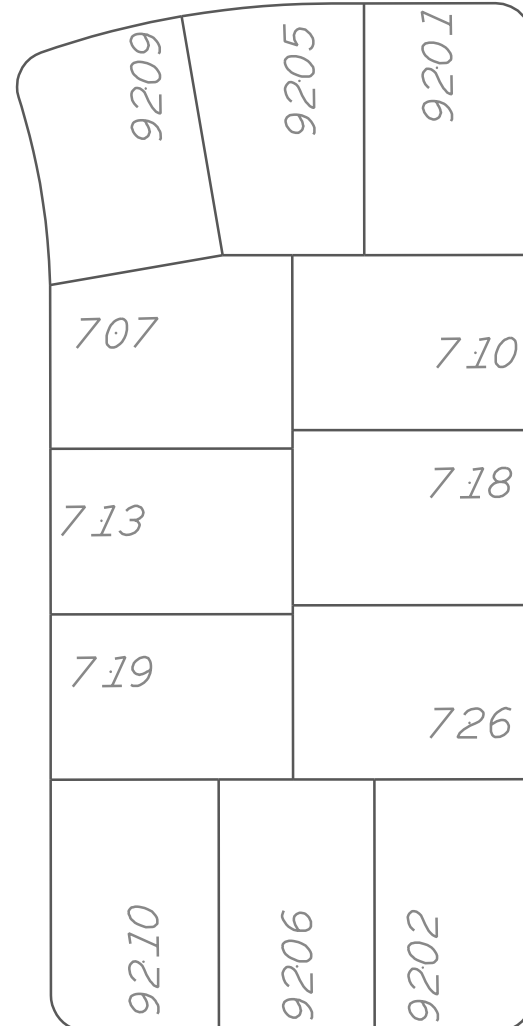
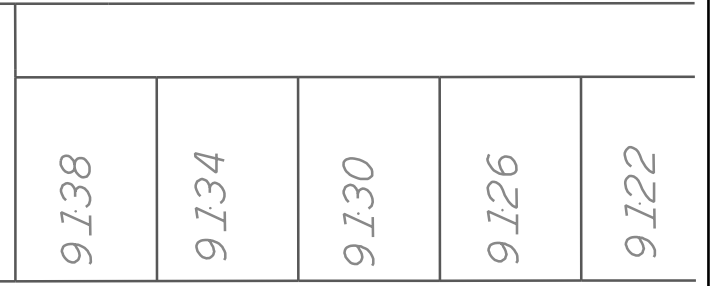
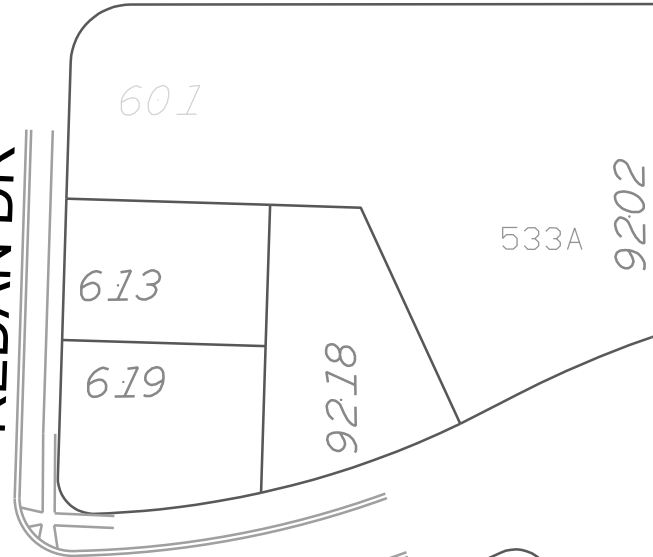
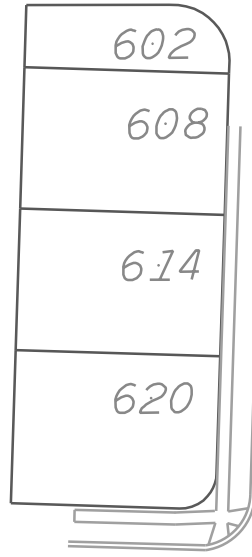

PLOT SCALE: _____

PLOT NAME: _____

REV. DATE: _____

ORIGINATOR: CITY OF MADISON, STREETS DIVISION

- NOTES:
1. ALL CURB & GUTTER ON THE ISLANDS SHALL BE TYPE 'E' PER S.D.D. 3.08
 2. ALL ISLANDS SHALL HAVE CONCRETE MOUNTABLE NOSES PER S.D.D. 3.13
 3. INTERIOR OF ISLANDS SHALL BE 7" STAMPED & COLORED CONCRETE (6"x6" COBBLESTONE, NATURAL BARK)
 4. SAWCUT EXISTING PAVEMENT AT PROPOSED EDGE OF GUTTER. TAKE CARE TO NOT DAMAGE PAVEMENT BEYOND THAT POINT.
 5. CONTRACTORS SHALL COORDINATE WITH TRAFFIC ENGINEERING TO LAYOUT ISLANDS IN THE FIELD
 6. PAVEMENT MARKINGS BY OTHERS

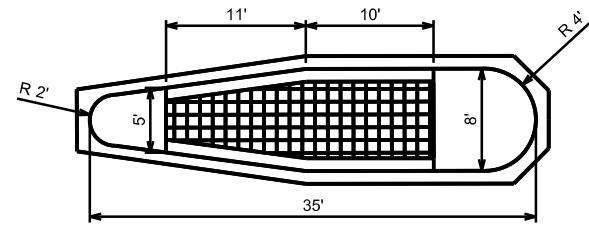

5901

5801

5602

TOKAY BLVD

INSTALL ADA COMPLIANT PED RAMPS
REMOVE & REPLACE CURB AS NECESSARY
TAKE CARE TO NOT DAMAGE PAVEMENT
REMOVE & REPLACE SIDEWALK AS NECESSARY

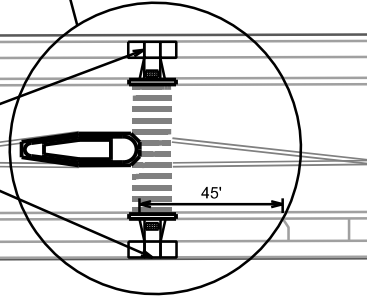

5725

5727

5721

620

PLOT SCALE: _____

PLOT NAME: _____

REV. DATE: _____

ORIGINATOR: CITY OF MADISON, STREETS DIVISION

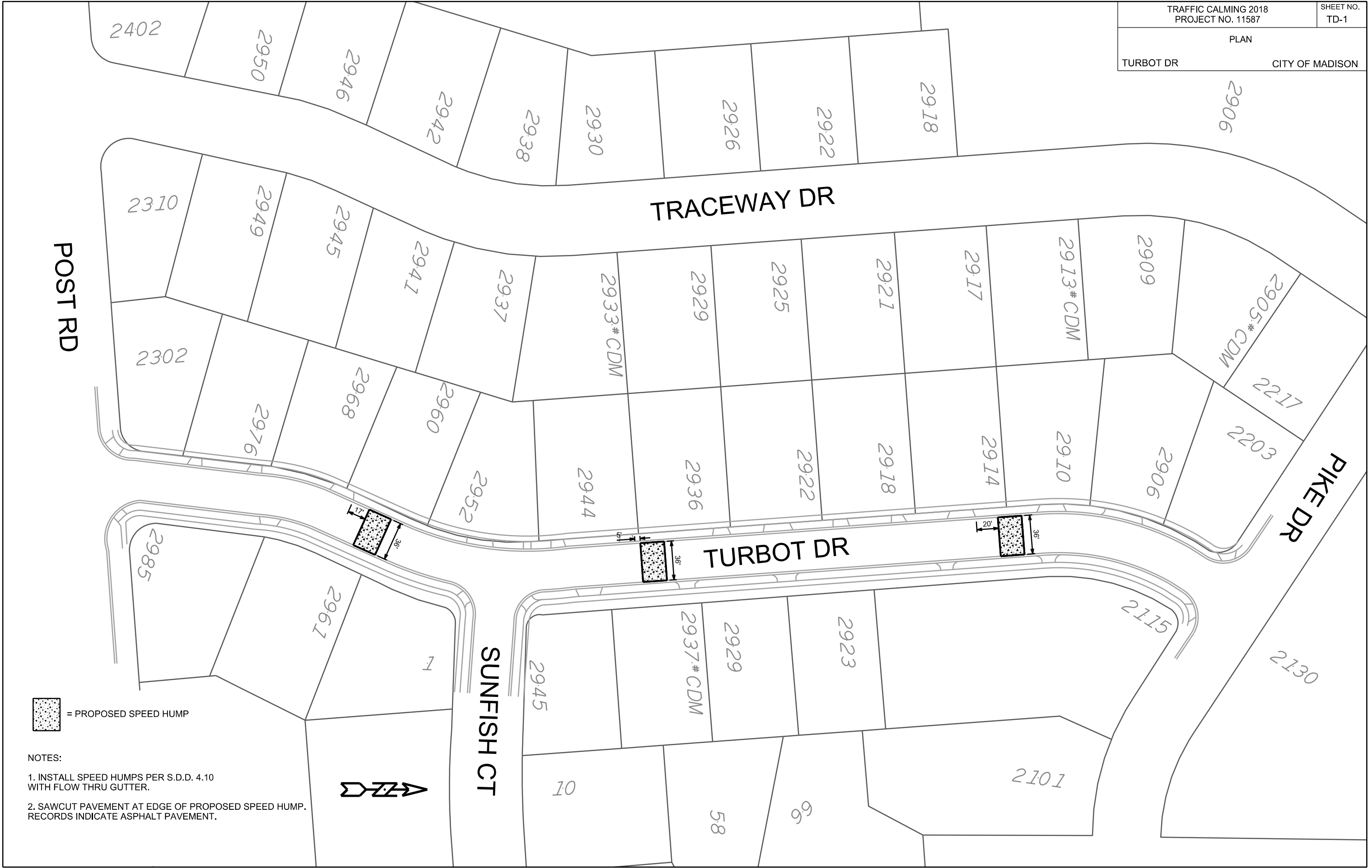

 = PROPOSED SPEED HUMPS

- NOTES:
1. INSTALL SPEED HUMPS PER S.D.D. 4.10 WITH FLOW THRU GUTTER.
 2. SAWCUT PAVEMENT AT EDGE OF PROPOSED SPEED HUMPS. RECORDS INDICATE ASPHALT PAVEMENT.



PLOT SCALE:

PLOT NAME:

REV. DATE:

ORIGINATOR: CITY OF MADISON, STREETS DIVISION



0709-184-1906-5
UNIVERSITY CROSSING LLC
5102 Silvertree Run

0709-184-1905-7
UNIVERSITY CROSSING
OFFICE LLC ATTN P LENHART
749 University Row

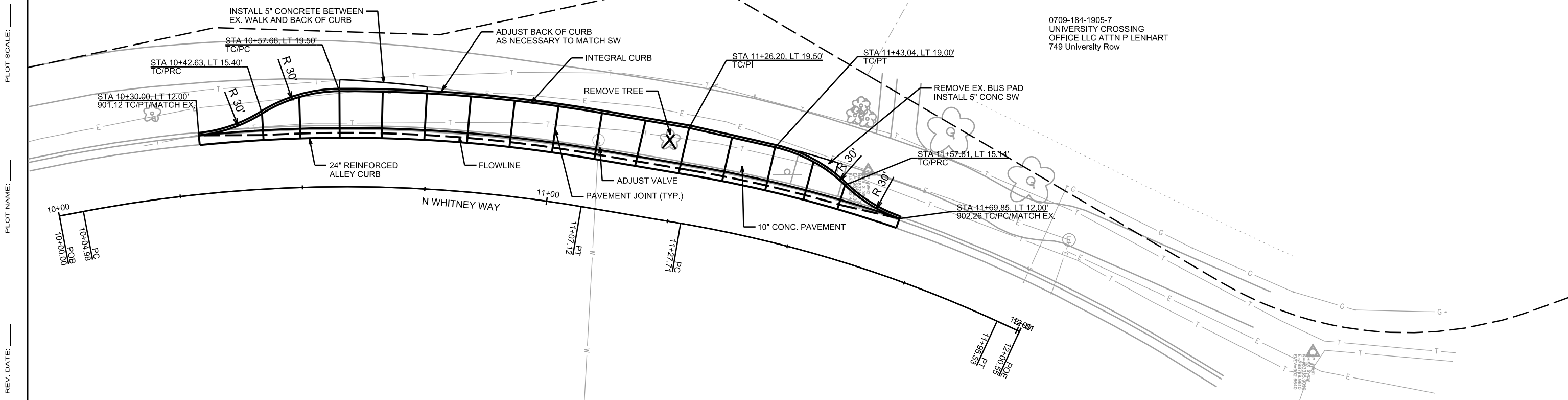

TYPICAL SECTION DETAIL
N WHITNEY WAY
NOT TO SCALE

INTEGRAL CONCRETE CURB DETAIL
NOT TO SCALE

REINFORCED ALLEY CURB DETAIL
NOT TO SCALE

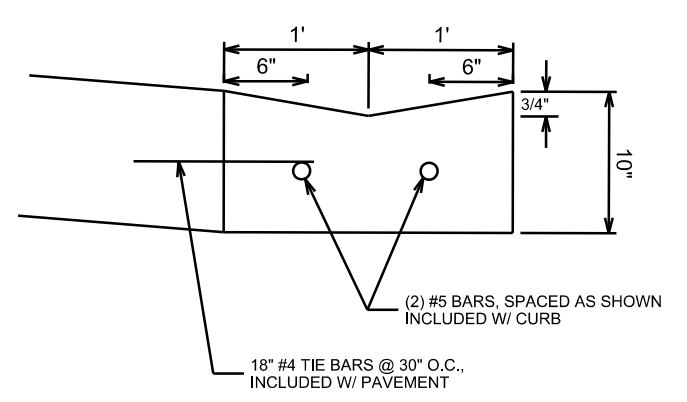
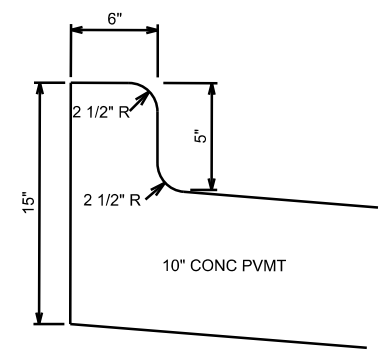
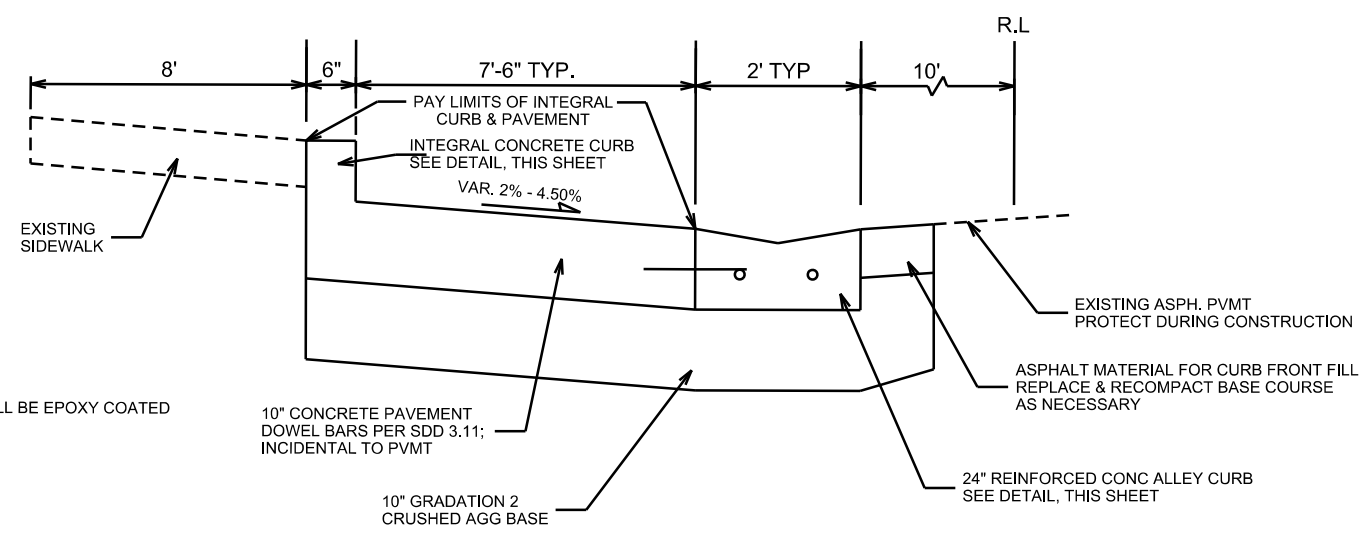

NOTE: ALL BARS SHALL BE EPOXY COATED

ORIGINATOR: CITY OF MADISON, STREETS DIVISION